

CONNECTING “PASSIVE” TAP TO T1

“Passive” tap enables **Replay Call Recording** system to connect to a T1 without interfering with T1’s operation. Each “passive” tap comes shipped with one WHITE cable, one YELLOW cable, and one GREEN cable. Depending on the number of T1’s, Replay PC may be shipped with one or two “passive” tap sets.

1. Remove the cover from the “passive” tap, exposing two internal RJ45 connectors. These are the “NET” and “PBX” connectors.
2. Disconnect the T1 cable from your PBX, and plug it into the “NET” connector on the tap.
3. Plug one end of the WHITE cable, provided with the system, into the “PBX” connector on tap.
4. Put the cover back on the “passive” tap. The “NET” and “PBX” labels should match corresponding cable connections.
5. Plug the other end of the WHITE CABLE into PBX.

6. The GREEN and YELLOW cables come shipped already attached to the “passive” tap, Port 1 and Port 2 respectively. Plug the YELLOW cable to the Upper Port and the GREEN cable to the Lower ports, which are located on the back of the Replay box.
7. If you have two T1’s you should have received two “passive” tap sets. Repeat instructions 1-6 for the second “passive” tap.

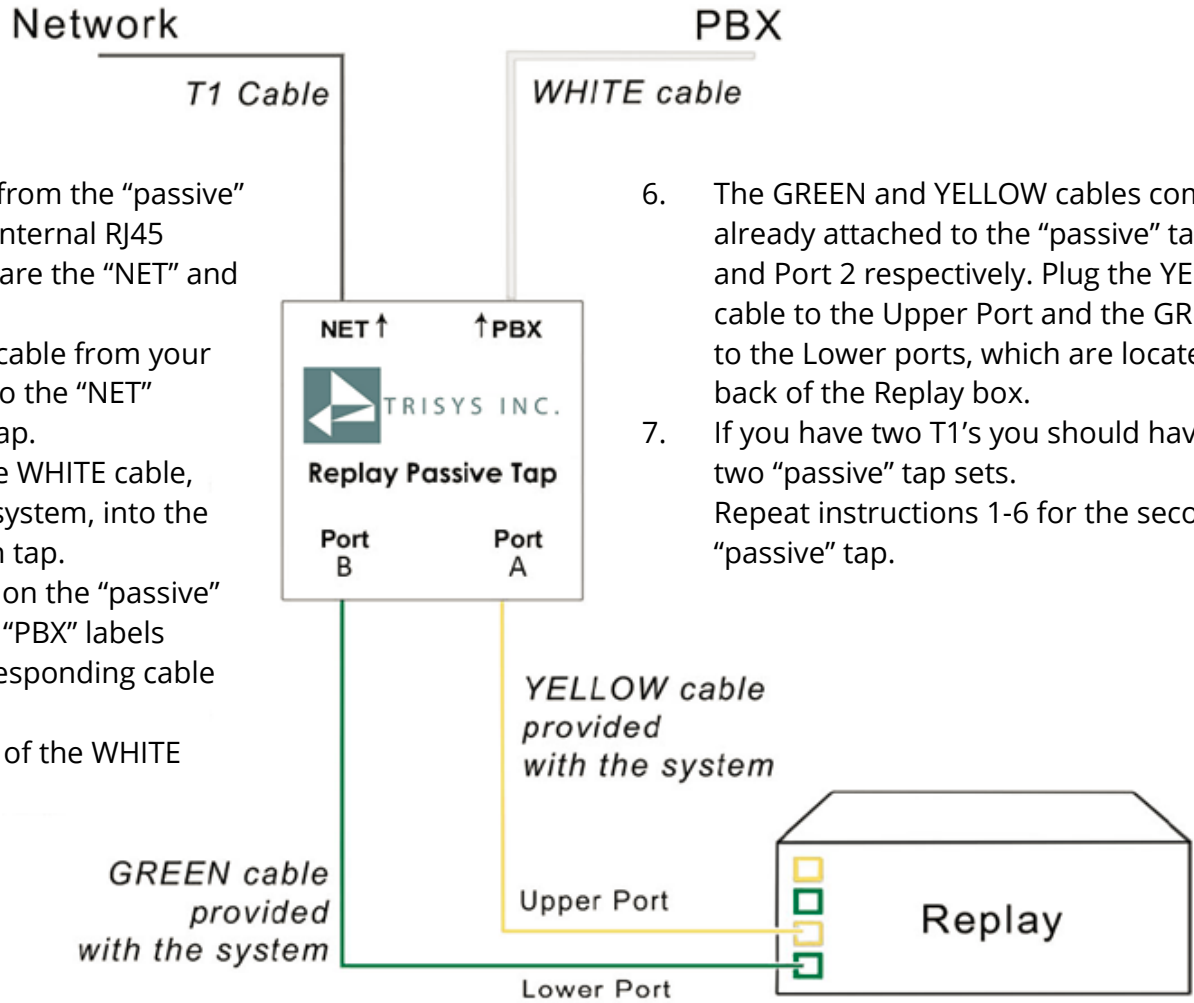



TRISYS INC.

Trisys Inc.
215 Ridgedale Avenue
Florham Park, NJ 07932

www.trisys.com

Phone: 973-360-2300
Fax: 973-360-2222
Email: general@trisys.com