

### CONNECTING THE PASSIVE TAP TO T1

The passive tap enables the **Replay Call Recording** system to connect to a T1 without interfering with the T1's operation. Each passive tap comes shipped with two cables. Depending on the number of T1's, Replay PC may be shipped with one or two passive tap sets.

1. Remove the cover from the passive tap, exposing two internal RJ45 connectors. These are the "NET" and "PBX" connectors.
2. Disconnect the T1 cable from your PBX, and plug it into the "NET" connector on the tap.
3. Plug one end of the WHITE cable, provided with the system, into the "PBX" connector on tap.
4. Put the cover back on the "passive" tap. The "NET" and "PBX" labels should match corresponding cable connections.
5. Plug the other end of the WHITE cable into PBX.

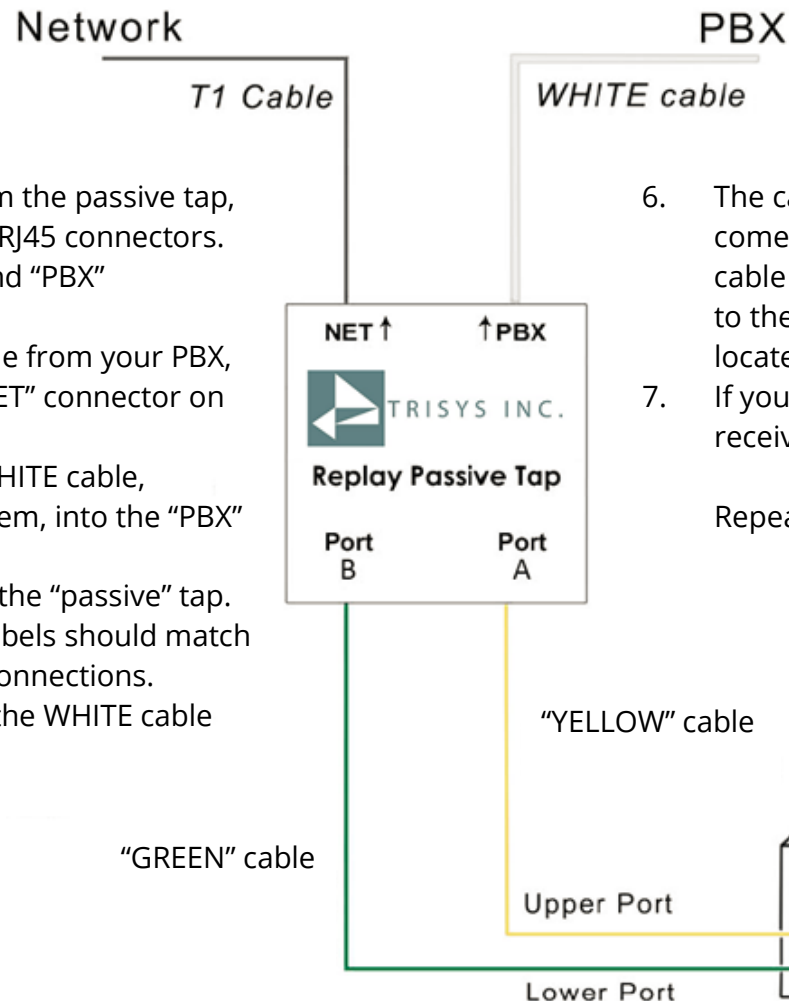

6. The cables depicted as "YELLOW" and "GREEN" come with the system. Connect the "YELLOW" cable to the Upper Port and the "GREEN" cable to the Lower port of the PRI card, which is located on the back of the Replay box.
7. If you have a dual PRI system, you should have received two passive taps, one for each PRI.

Repeat instructions 1-6 for the second tap.